

# HOT-WIRE AND HOT-FILM ANEMOMETRY

## INTRODUCTION

The hot-wire anemometer has been used extensively for many years as a research tool in fluid mechanics. In this paper hot-wire anemometry will refer to the use of a small, electrically heated element exposed to a fluid medium for the purpose of measuring a property of that medium. Normally, the property being measured is the velocity. Since these elements are sensitive to heat transfer between the element and its environment, temperature and composition changes can also be sensed.

Figure 1 shows a hot-wire anemometer probe. Typical dimensions of the wire sensor are 0.00015 to 0.0002 inches (0.0038 to 0.005 mm) in diameter and 0.040 to 0.080 inches (1.0 to 2.0 mm) long. This is the type of hot wire that has been used for such measurements as turbulence levels in wind tunnels, flow patterns around models and blade wakes in radial compressors. The film type of sensor is shown in Figure 2. The hot film is used in regions where a hot wire probe would quickly break such as in water flow measurements. More detailed descriptions of film sensors and a comparison between hot wires and films will be presented below.

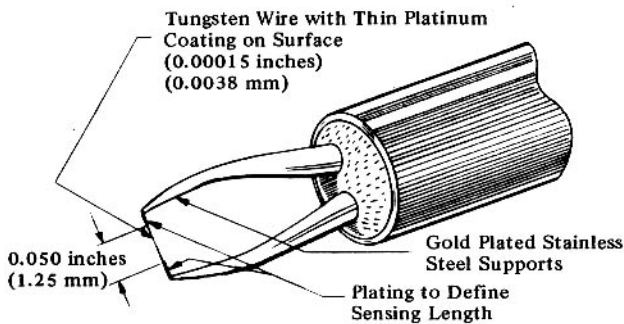

Figure 1: Tungsten Hot Wire Sensor and Support Needles- 0.00015" Dia. (0.0038 mm)

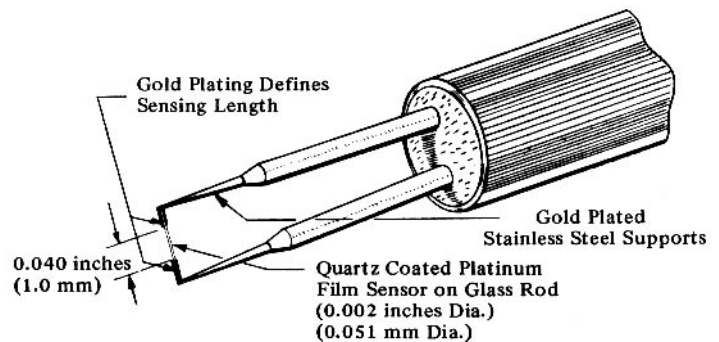

Figure 2: Cylindrical Hot Film Sensor and Support Needles- 0.002" Dia. (0.051 mm)

You will be using a Constant Temperature Anemometer (CTA). It works based on the fact that the probe's resistance will be proportional to the temperature of the hot wire. The bridge circuit shown in Figure 3 below is set up by setting the adjustable resistor to the resistance you wish the probe and its leads to have during operation. (The other two legs of the bridge have identical resistance.) The servo amplifier tries to keep the error voltage zero (meaning the resistances of the two lower legs of the bridge match). It will adjust the bridge voltage such that the current through the probe heats it to the temperature which gives the selected resistance. When we put the probe in a flow, the air (or water) flowing over it will try to cool it. In order to maintain the temperature (resistance) constant, the bridge voltage will have to be increased. Thus, the faster the flow, the higher the voltage. A very fine hot wire by itself cannot respond to changes in fluid velocity at frequencies above about 500 Hz. By compensating for frequency lag with a non-linear amplifier this response can be increased to values of 300 to 500 kHz.

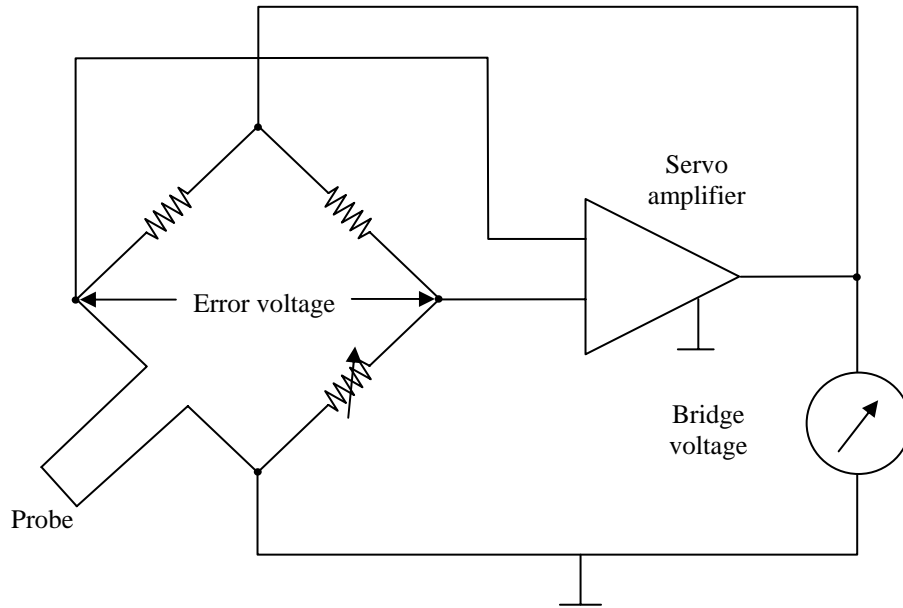

Figure 3: CTA bridge circuit

## PROBE TYPES

### 1. Hot-Wire Sensors

A hot-wire type sensor must have two characteristics to make it a useful device:

- A high temperature coefficient of resistance
- An electrical resistance such that it can be easily heated with an electrical current at practical voltage and current levels.

The most common wire materials are tungsten, platinum and a platinum-iridium alloy. Tungsten wires are strong and have a high temperature coefficient of resistance, ( $0.004/^{\circ}\text{C}$ ). However, they cannot be used at high temperatures in many gases because of poor oxidation resistance. Platinum has good oxidation resistance, has a good temperature coefficient ( $0.003/^{\circ}\text{C}$ ), but is very weak, particularly at high temperatures. The platinum-iridium wire is a compromise between tungsten and platinum with good oxidation resistance, and more strength than platinum, but it has a low temperature coefficient of resistance ( $0.00085/^{\circ}\text{C}$ ). Tungsten is presently the more popular hot wire material. A thin platinum coating is usually applied to improve bond with the plated ends and the support needles.

### 2. Hot-Film Sensors

The hot-film sensor is essentially a conducting film on a ceramic substrate. The sensor shown in Figure 2 is a quartz rod with a platinum film on the surface. Gold plating on the ends of the rod isolates the sensitive area and provides a heavy metal contact for fastening the sensor to the supports. When compared with hot wires the cylindrical hot-film sensor has the following advantages:

- Better frequency response (when electronically controlled) than a hot wire of the same diameter because the sensitive part of the sensor is distributed on the surface rather than including the entire cross section as with a wire.
- Lower heat conduction to the supports (end loss) for a given length to diameter ratio due to the low thermal conductivity of the substrate material. A shorter sensing length can thus be used.
- More flexibility in sensor configuration. Wedge, conical, parabolic and flat surface shapes are available.
- Less susceptible to fouling and easier to clean. A thin quartz coating on the surface resists accumulation of foreign material. Fouling tends to be a direct function of size.

The metal film thickness on a typical film sensor is less than 1000 Angstrom units, causing the physical strength and the effective thermal conductivity to be determined almost entirely by the substrate material. Most films are made of platinum due to its good oxidation resistance and the resulting long-term stability. The ruggedness and stability of film sensors have led to their use for many measurements that have previously been very difficult with the more fragile and less stable hot wires.

### PROBE SHAPES

In the comparison of hot-wire and hot-film probes the discussion was limited to cylindrical shapes. In addition to the cylindrical shape, hot films have been made on cones, wedges, parabolas, hemispheres, and flat surfaces. Cylindrical film sensors that are cantilever mounted are also made. This is done by making the cylindrical film sensor from a quartz tube and running one of the electrical leads through the inside of the tube. Figure 4 shows an example of a single ended sensor. This is an important modification for fluidic applications since they can be made very small and inserted into very small channels. Also, for omni-directional measurements (e.g., meteorology applications when the vertical flow can be ignored), it permits unobstructed flow from all directions.

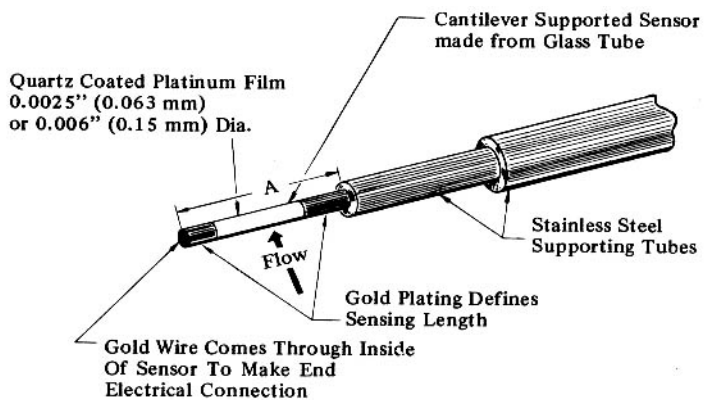

Figure 4: Single Ended Type Sensor

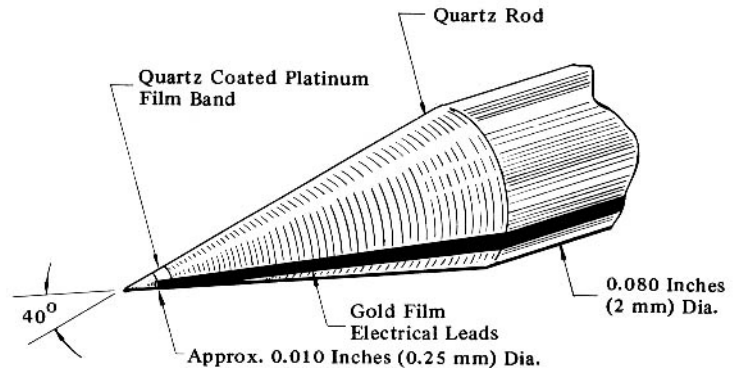

Figure 5: Hot Film Cone Probe

A cone shaped sensor is shown in Figure 5. This sensor is used primarily in water applications where its shape is particularly valuable in preventing lint and other fibrous impurities from getting entangled with the sensor. The cone can be used in relatively contaminated water, while cylindrical sensors are more applicable when the water has been

filtered. Figure 6 shows a flush mounted probe which has been used for sensing the presence of flow with no obstruction in the fluid passage, detecting whether the boundary layer is laminar or turbulent, and measurements of shear stress at the wall. It makes a very rugged probe when compared with other anemometer type sensors.

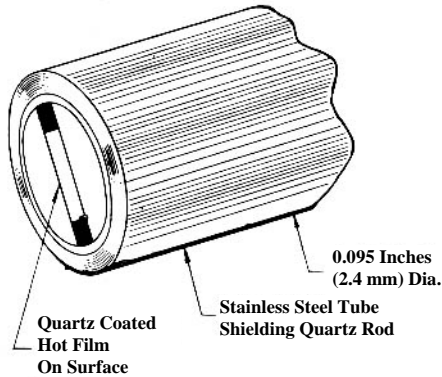

Figure 6: Hot Film Flush Mounted Probe

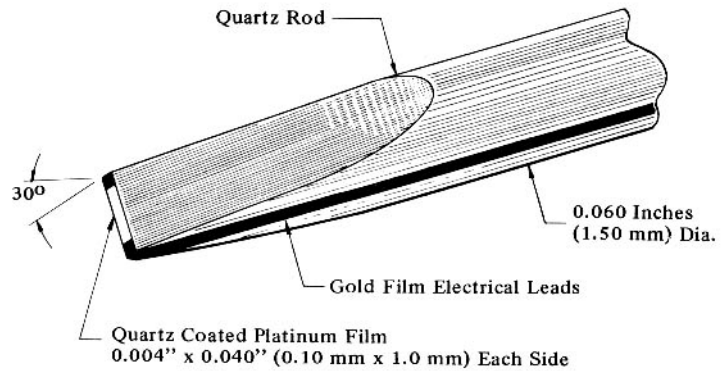

Figure 7: Hot Film Wedge Probe

The wedge shaped probe shown in Figure 7 has been used for both gaseous and liquid applications. It is somewhat better than cylindrical sensors when used in contaminated water and is certainly stronger than cylindrical sensors for use in very high velocity air or water where there is a large load on the sensor due to fluid forces.

### TEST SETUP

In this week's experiment, you'll be using a hot-wire anemometer to analyze the flow in the wake of a circular cylinder in crossflow. The open-throat wind tunnel will be used for the experiment. (Flow measurements in water are usually done with a hot-film anemometer like the one in Figure 4. The basic principles are the same regardless of whether the working fluid is air or water.) A cylinder will be placed across the throat of the tunnel and the measurements will be taken using the hot-wire anemometer probe mounted downstream of the cylinder on a traverse mechanism. The traverse mechanism makes it possible to remotely move the probe vertically through the wake of the cylinder.

You will be using a DANTEC constant temperature anemometer (CTA) unit with a hot-wire probe made by Thermo-Systems Inc. Data acquisition will be done utilizing LabVIEW running on your own computer and a USB DAQ card. Note the make and model of this DAQ card. You should be familiar with it and its properties from your experience in AOE 3054. The supplied vi will run this card in differential acquisition mode over a maximum input A/D range of  $\pm 5$  Volts DC.

### FUNDAMENTAL DATA ANALYSIS

The anemometer is capable of reading instantaneous values of velocity up to very high frequencies. Therefore it responds to and is capable of measuring the turbulent fluctuations in the flow field. (Most velocity measuring instruments, such as the pitot-static tube, respond very slowly effectively giving an average velocity over some longer time.) The actual time dependence of an unsteady, turbulent flow is usually too unwieldy to provide information

directly, so various types of time averages are used to interpret the data. You were introduced to many of these in AOE 3054. Some of the most basic types of time averages are reviewed below.

The mean level of a signal  $u(t)$ , which may represent the streamwise velocity component, is denoted  $\bar{u}$ , defined as

$$\bar{u} = \lim_{T \rightarrow \infty} \frac{1}{T} \int_0^T u(t) dt = \text{Mean} \quad (1)$$

In practice, the sample time period  $T$  is always finite so actual measurements only approximate this definition. The mean square of the same signal is computed by first squaring the signal and then taking the time average:

$$\overline{u^2} = \lim_{T \rightarrow \infty} \frac{1}{T} \int_0^T u^2(t) dt = \text{Mean Square} \quad (2)$$

Taking the time average of the square of the fluctuation of the signal about the mean yields the variance of the signal,  $\sigma^2$ , defined as:

$$\sigma^2 = \overline{(u - \bar{u})^2} = \text{Variance} \quad (3)$$

Simple manipulation gives (try this):

$$\sigma^2 = \overline{u^2} - (\bar{u})^2 \quad (4)$$

Equation (4) says that the variance is the mean square level minus the square of the mean level. (Note that the mean square is not the same as the square of the mean.)

It is often convenient to take the square root of the variance. This is referred to as the standard deviation or the root mean square (RMS) value, i.e.,

$$\sigma = \sqrt{\sigma^2} = \text{Standard Deviation} = \text{RMS} \quad (5)$$

## EQUIPMENT

- Open throat wind tunnel and circular cylinder model
- Hot-wire probe (TSI type 1210T1.5), probe support and traverse
- DANTEC 56C constant temperature anemometer (CTA) unit
- Computer with LabVIEW software
- USB DAQ card
- Reference pitot-static probe and electronic manometer
- Oscilloscope

Be sure to note make and model number of all the equipment you use.

**CAUTION** - The hot-wire probe is extremely delicate and will break at the slightest touch or electrical pulse. Take great care to avoid it and always set the bridge selector to STD BY when not actually making measurements.

## HOT-WIRE CALIBRATION

The hot-wire responds according to King's Law:

$$E^2 = A + Bu^n \quad (6)$$

where  $E$  is the voltage across the wire,  $u$  is the velocity of the flow normal to the wire and  $A$ ,  $B$ , and  $n$  are constants. You may assume  $n = 0.45$ , this is common for hot-wire probes (although in a research setting, you should determine  $n$  along with  $A$  and  $B$ ).  $A$  and  $B$  can be found by measuring the voltage,  $E$ , obtained for a number of known flow velocities and performing a least squares fit for the values of  $A$  and  $B$  which produce the best fit to the data. (The Hot-Wire Lab VI operating in calibration mode will give you the voltage across the wire.) By defining  $u^n = x$  and  $E^2 = y$ , this least squares fit becomes simply a linear regression for  $y$  as a function of  $x$ . The values of  $A$  and  $B$  depend on the settings of the anemometer circuitry, the resistance of the wire you are using, the air temperature, and, to a lesser extent, the relative humidity of the air. An example calibration is given below. Microsoft Excel is used to make the calculations in the example but you are free to use whatever means of making them that you prefer.

Note that the uncertainty in the determination of the mean flow velocities (which are obtained from the tunnel pitot-static tube) implies an uncertainty in the calibration and thus in the velocities obtained from the hot-wire probe. (Calculating the uncertainties in a velocity obtained from a pitot-static probe was used as an example in AOE 3054. To refresh your memory, see the online lecture "Estimating Experiment Error" which will be posted to the website for this lab.) While it is possible to perform a formal analysis of how these uncertainties work their way through the calibration calculations to result in uncertainties in  $A$  and  $B$ , and thus in the velocities calculated from the hot-wire anemometer, you will find that these uncertainties are essentially the same as the uncertainties in the velocities used in the calibrations. (This is true as long as your King's law velocity prediction reproduces the calibration velocities to within the uncertainty on them. If it does not, you will need to assume a larger uncertainty in the velocities obtained from the hot-wire.) You can confirm this by assuming that the lowest three calibration velocities were actually at their upper or lower uncertainty limits, redoing the fit for  $A$  and  $B$  and comparing the velocities you would have calculated with the new  $A$  and  $B$  with what you obtained with the original  $A$  and  $B$ . Throughout this procedure, we will be assuming that the uncertainties in the measured voltages are negligible compared to the uncertainties in the calibration velocities. Since the voltages you will be using are actually averages of a randomly fluctuating quantity, we are assuming that you are averaging a sufficiently large number of samples that any sampling error is negligible.

We assume that you have collected the following calibration data with the ambient pressure,  $p_{atm} = 985$  mb and ambient temperature,  $T_{atm} = 26.7$  °C.

Table 1. Calibration data

$\Delta p$  (in. H<sub>2</sub>O)     $E$  (volts)

0.17	2.979
0.251	3.076
0.53	3.249
0.776	3.36
1.036	3.44
1.55	3.554
2.07	3.655
2.47	3.707

$\Delta p$  is the difference between the stagnation and static pressures (the dynamic pressure) measured by the pitot-static tube and electronic manometer. A number of calculations have been made with this data in the table below. First,  $\Delta p$  is converted from inches of water to Pa and a velocity,  $u$ , is calculated that corresponds to each  $\Delta p$  (note that this calculation uses the ideal gas law to find the density of air). The uncertainty in velocity,  $\delta(u)$ , is calculated following the procedure in the “Estimating Experiment Error” lecture from AOE 3054. In that lecture, you were shown that the contribution to  $\delta(u)$  from the errors in the atmospheric pressure and temperature measurements were negligible compared to the contribution from the measurement of  $\Delta p$ . Consequently, only the later has been considered in the calculations below. Further, it has been assumed that the electronic manometer you will be using for this lab has the same uncertainty as that assumed for the electronic manometer used in AOE 3054 (20 Pa). You should estimate the uncertainty of the manometer you will be using by observing its behavior during your lab and use that uncertainty for your own data reduction. In the next column, the uncertainty in  $u$  is divided by  $u$ . You can see that the uncertainty is a large percentage of the calculated velocity at small velocities but this percentage decreases significantly at larger velocities. This is because the same uncertainty in  $\Delta p$  is used over the full range of velocities. You should take note during your lab whether or not this is the case.

Table 2. Calibration data analysis

$\Delta p$ (in. H <sub>2</sub> O)	$\Delta p$ (Pa)	$u$ (m/s)	$\delta(u)$ (m/s)	$\delta(u)/u$	E(volts)	$E^2$	$u^n$	$u$ pred
0.17	42.346	8.600	2.031	0.236	2.979	8.874	2.633	8.572
0.251	62.523	10.450	1.671	0.160	3.076	9.462	2.875	10.595
0.53	132.021	15.185	1.150	0.076	3.249	10.556	3.401	15.001
0.776	193.298	18.374	0.951	0.052	3.360	11.290	3.706	18.433
1.036	258.063	21.230	0.823	0.039	3.440	11.834	3.955	21.231
1.55	386.098	25.968	0.673	0.026	3.554	12.631	4.330	25.728
2.07	515.628	30.009	0.582	0.019	3.655	13.359	4.621	30.252
2.47	615.266	32.780	0.533	0.016	3.707	13.742	4.809	32.794

The remaining columns contain the voltage data,  $E^2$  and  $u^n$  (calculated because we will be fitting a curve to these to determine our calibration coefficients,  $A$  and  $B$ ) and the value of velocity predicted by King’s law using the values of  $A$  and  $B$  that were determined.

As discussed above,  $A$  and  $B$  are determined as the coefficients of a linear regression to  $E^2$  as a function of  $u^n$ . The plot in Figure 8 was made from the appropriate columns of Table 2 and using the trend line feature of Excel. From Figure 8, we see that  $A = 3.0035$  and  $B = 2.2327$  yields a very good match to the calibration data.

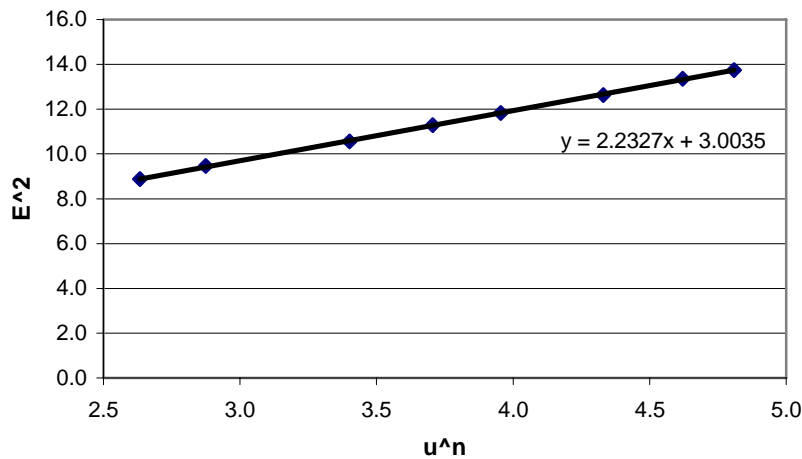

Figure 8: Trendline plot to calibration data determining  $A$  and  $B$ .

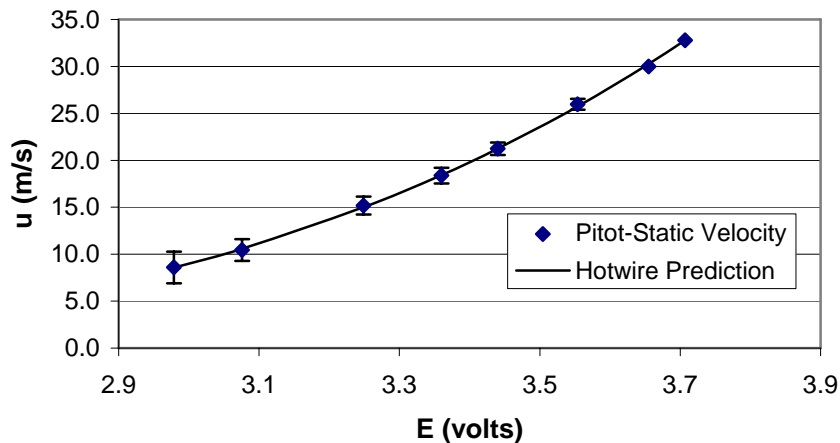

Figure 9: King's law prediction for velocity using the values of  $A$  and  $B$  determined in Figure 8 compared to the calibration data. Note the error bars on the data. The uncertainty in the King's law prediction will be similar.

Figure 9 shows a comparison of the velocity predicted by King's law using the values of  $A$  and  $B$  that were determined above to the calibration data. Note the error bars on the plot. These are taken directly from the  $\delta(u)$  column in Table 2 (Excel does this).

You should follow this procedure to calibrate the wire before you perform your lab. It will help you to have a spreadsheet or MatLab program available to do this calculation. It should include plots similar to Figures 8 and 9. You will create this as part of the pre-lab question that needs to be turned in at the start of lab. You will find the assignment below.

### TEST PROCEDURE

1. Connect the hot-wire probe lead to the probe connector on the CTA bridge.
2. Connect the DAQ card and oscilloscope inputs to the anemometer output, which is on the back of the anemometer mainframe.
3. Be sure the bridge selector switch on the anemometer is set to STD BY (stand by).

4. Turn on all equipment (the anemometer switch is on the back, DOWN is power ON).
5. On the computer, open Hot Wire Lab.llb and load Hot Wire Lab DAQmx.vi. the following files by double clicking on the desktop icons (these may already be open).
  - a) "Hot Wire Lab.vi"
  - b) "Tunnel Q.vi"
6. The first step in the lab procedure is calculating the hot-wire constants  $A$  and  $B$ .
  - a) Run the VI "Tunnel Q" by clicking the "Run" button in the upper left hand corner of the window (looks like an arrow). This will display the current tunnel  $Q$  (which should be near zero since the tunnel is off).
  - b) The displayed value may not be zero, depending on the atmospheric pressure, so while the VI is running you may depress the button labeled 'Zero Manometer'. This will measure the offset and correct the tunnel  $Q$  to read zero.
  - c) Press the STOP button on the "Tunnel Q" VI once you are satisfied that the displayed  $Q$  is zero.
  - d) Now, switch over to the "Hot Wire Lab" VI and;
    - i) Click the MODE switch to CALIB (the switch will turn yellow)
    - ii) Enter the parameter values of 5000 Samples, Sample Rate = 500
    - iii) The other switch setting does not matter, nor do the other inputs — for now.
  - e) For the wire calibration, you will be running the tunnel at a number of speeds spanning the full range of speeds you can get from the tunnel. Move the traverse so that the wire is positioned in the free stream, well outside of the cylinder wake. Once you have flow in the tunnel, turn the CTA switch to FLOW. For each speed:
    - i) Note the tunnel  $Q$ .
    - ii) Click the "Run" button on the Hot Wire VI.
    - iii) The VI will sample the hot-wire output for 10 seconds (5000 Samples @ 500 Samples/sec) and will plot the signal on the graph. Below the graph will be the mean (average) VOLTAGE recorded, the RMS of that voltage and the RMS/Mean. Note the mean voltage. Insure that the RMS is a small fraction of the mean (low turbulence in the free stream).
  - f) Turn the CTA to STD BY.
  - g) Obtain the calibration coefficients  $A$  and  $B$  from your calibration calculations.
7. You are now ready to take wake velocity profile measurements.
  - a) Run the "Tunnel Q" VI and affirm that the tunnel speed is at  $Q = 0.5$  in.  $H_2O$ , then STOP the "Tunnel Q" VI.
  - b) Switch over to the Hot Wire VI and set the following values
    - i) MODE switch to DATA (it will turn gray in color)
    - ii) 'Save Unsteady' switch to NO
    - iii) Enter the constants  $A$  and  $B$  into the control boxes (you may leave  $n$  as its default value of 0.45). Also enter the velocity UNITS into the appropriate control box (e.g., "ft/s" or "m/s" corresponding to your calibration).
    - iv) Set the DAQ parameters to 1000 Samples, Sample Rate=500 Hz.
  - c) Move the traverse DOWN to a point below the cylinder (about  $z = -5.0$  inches works well).
  - d) Turn the CTA switch to FLOW.

- e) Run the Hot Wire VI and enter a Data File Prefix - This is the prefix for your data file. An extension will be added depending on the type of data being stored: \*.avg for averaged velocity data, and \*.dat for unsteady time history data. So, just choose a convenient directory; enter a prefix and click 'Save'.
  - f) A window will now appear named "Z Position Dialog". Enter the current  $z$  position of the probe traverse as read off the traverse scale.
  - g) Click the "Take Data" button. The small window will disappear and will return when the acquisition is complete.
  - h) Traverse the probe upward two 'clicks', and repeat steps 'f' and 'g' until the probe has been traversed up through the cylinder wake (up to about  $z = 9$  inches or so).
  - i) When you have finished the traverse of the probe, click "STOP" on the "Z Position Dialog" which will cease the DAQ process.
  - j) Turn the CTA switch to STD BY.
8. Collecting time history data at three points in the cylinder wake.
- a) Select the three points in the wake for detailed examination by looking at the data stored from the wake profile measurements (e.g., load it into WordPad). These points should be;
    - i) Free Stream — turbulence intensity should be less than 5% (0.05)
    - ii) Center of cylinder wake
    - iii) Location of maximum turbulence intensity
  - b) Set the 'Save Unsteady' switch in the Hot Wire VI to YES. Leave the MODE switch in DATA mode. Leave all other settings.
  - c) Move the traverse to the desired  $z$  location.
  - d) Turn the CTA switch to FLOW
  - e) Run the Hot Wire VI
    - i) Enter a file prefix
    - ii) Enter the  $z$  position
    - iii) Click 'Take Data'
    - iv) When the window reappears, click 'STOP'
  - f) Turn the Hot Wire switch to STD BY.
  - g) Repeat steps 'c'-'f' for the other two points.
9. Repeat Steps 7 and 8 for a Tunnel Q over 2.5 inches of water.
10. Make sure the CTA switch is left in STD BY, turn all equipment (except the computer) off, and get copies of your data.
11. Be sure to note the cylinder diameter and the distance the probe is downstream of the center of the cylinder.

#### PRELAB QUESTION

Before you begin your lab, your lab instructor will collect your answer to the following question. Print a copy and bring it with you when you come to do the lab. It will be worth 10% of your lab grade. It is an honor code violation to hand in someone else's work as your own. You may work with others to discuss the procedure but everyone should assemble their own calculation.

Assume that you have collected the following calibration data with the ambient pressure,  $p_{atm} = 992$  mb and temperature  $T_{atm} = 23.4$  °C. Find the King's law coefficients and produce plots similar to those shown in Figures 8 and 9 above. Be sure to add error bars to your calibration velocities. Assume the manometer uncertainty is 20 Pa as was done above.

Table 3 Calibration data for prelab question

$\Delta p$ (in. H <sub>2</sub> O)	$E$ (volts)
0.15	2.93
0.21	3.05
0.44	3.22
0.74	3.35
1.01	3.46
1.47	3.56
1.89	3.65
2.42	3.72

You may find the following useful.

$$\Delta p = \frac{1}{2} \rho u^2$$

$$\rho = \frac{p}{RT}$$

$$R = 1716 \frac{\text{lb ft}}{\text{slug } ^\circ\text{R}} = 287 \frac{\text{N m}}{\text{kg K}}$$

$$^\circ\text{R} = 459.6 + ^\circ\text{F} \quad \text{K} = ^\circ\text{C} + 273.16$$

$$\gamma_{H_2O} = 62.43 \frac{\text{lb}}{\text{ft}^3} = 9806 \frac{\text{N}}{\text{m}^3}$$

$$1 \text{ mb} = 2.0884 \frac{\text{lb}}{\text{ft}^2} = 100 \text{ Pa}$$

### DATA PRESENTATION AND POINTS FOR DISCUSSION

Present and discuss your calibration procedure and uncertainty determination.

In plotting and presenting the data, normalize  $X$  (streamwise distance) and  $Y$  (vertical distance) on the cylinder diameter  $D$ . Normalize the mean velocity,  $u$ , and the RMS velocity fluctuation,  $\sigma$ , on the mean velocity measured at the edge of the wake  $u_e$ . Calculate values of Reynolds number for the two flows. Plot profiles of  $u/u_e$  and  $\sigma/u_e$  vs.  $Y/D$  for the two Reynolds numbers. (The quantity  $\sigma/u_e$  or, alternatively,  $\sigma/u$ , is sometimes called the turbulence intensity.)

Explain as well as you can the various profile shapes. Discuss differences between the two Reynolds number cases. Relate these differences to the pressure measurements you made on the cylinder last semester. Plot and describe the velocity variation with time data. In what way are the velocity fluctuations different at the different locations and Reynolds numbers? In all, what do the hot-wire measurements tell you about the unsteady structure of the flow past a cylinder?

Sample plots are shown in Figures 8 and 9. Note that plots of experimental data should consist of symbols connected by straight lines – no curves between points.

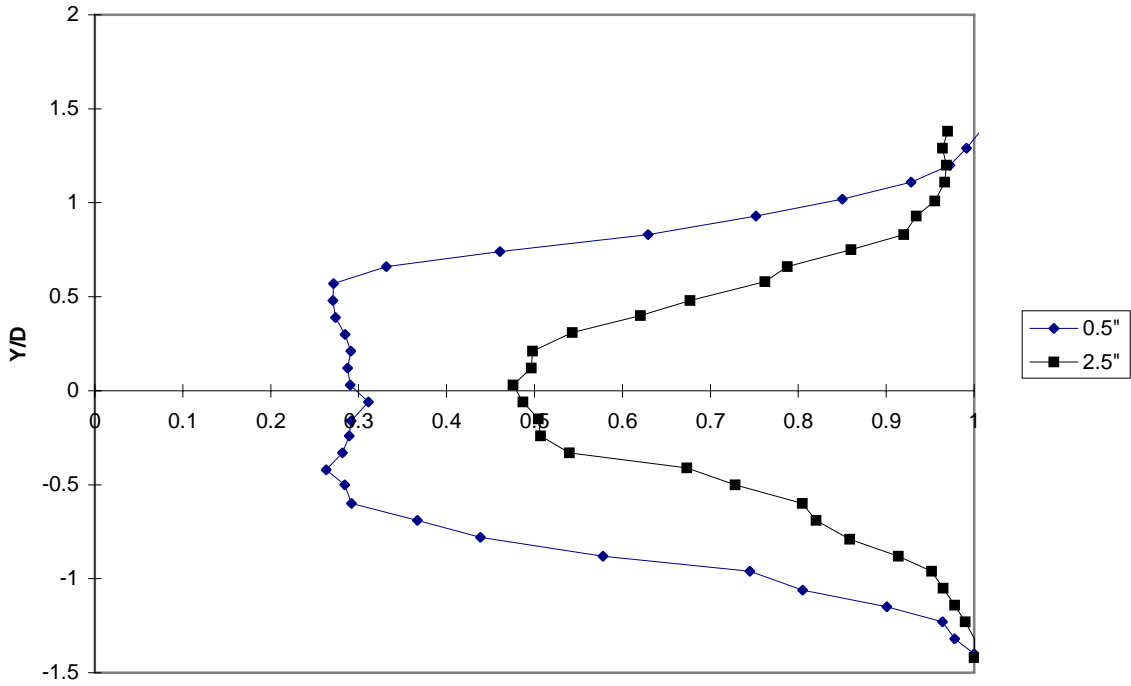

Figure 10:  $U/U_\infty$  for  $h=0.5''$  and  $2.5''$  of water

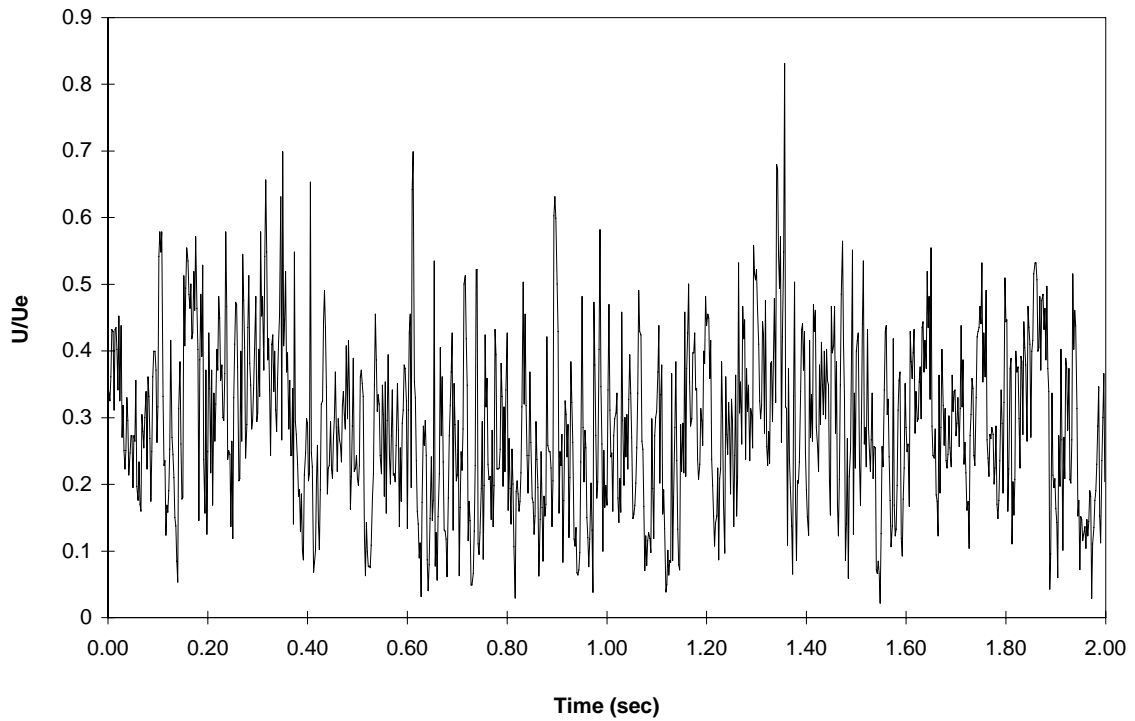

Figure 11: Time-History data for Flow Velocity behind centerline of cylinder,  $h=0.5''$

## Report Expectations for Hot-Wire Lab

Prelab Question - collected before lab (10 pts.)

Title Page and Abstract

Introduction

Description of Experiment

- A. Describe hot-wire anemometer (with operating principle).
- B. Describe type of probe used.
- C. Mention wind tunnel, traverse, computer with A/D board and oscilloscope.
- B. Discuss calibration procedure.
- D. Discuss the procedure of traversing the probe through the wake.
- E. Discuss the three locations at which the raw data was stored.
- F. Discuss the two tunnel speeds
- G. Give cylinder diameter and distance probe was downstream

Calibration and Uncertainty Determination (with plots)

Results of Experiment

- A. Define RMS velocity fluctuation.
- B. Plots of  $u/u_e$  and  $\sigma/u_e$  vs  $Y/D$  with explanation of shapes.
- C. Calculate Reynolds numbers for each case and discuss laminar vs, turbulent separation. Mention pressure measurements made last semester.
- D. Plots of velocity vs. time with explanation of differences.

Conclusion

Repeat major findings.

What did the lab show you?